

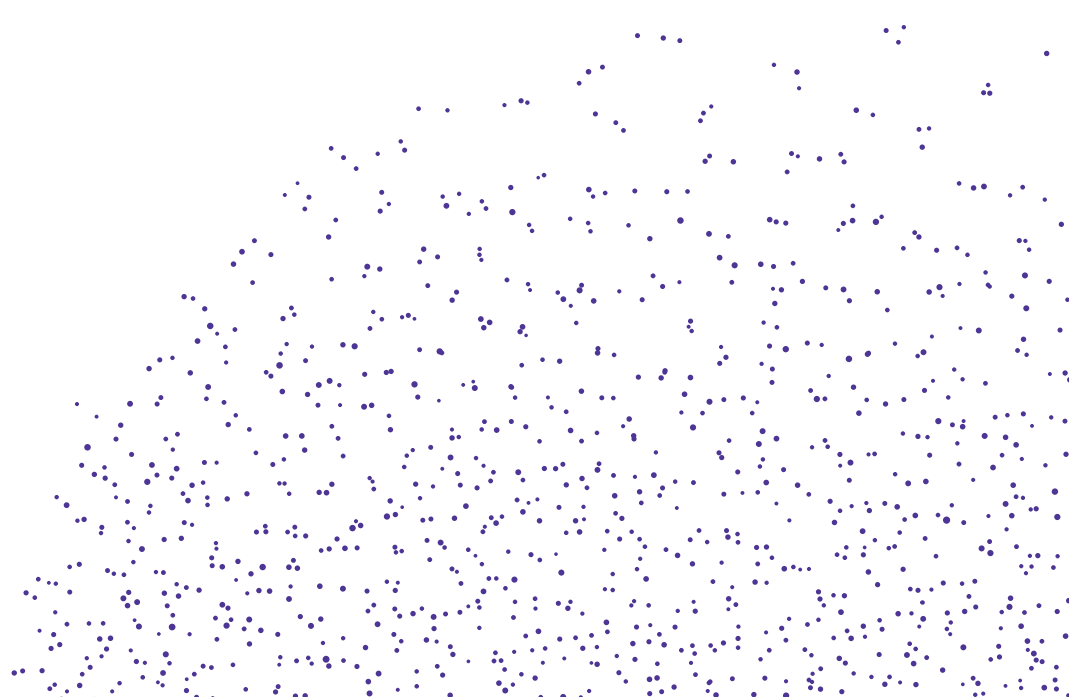

Nel Hydrogen Electrolysers

The World's
Most Efficient
and Reliable
Electrolysers



Empowering generations with clean energy forever is the vision of Nel Hydrogen.

Our technology allows people and businesses to make everyday use of hydrogen, the most abundant element in the universe.

Nel Hydrogen Electrolysers

With more than 3,800 reliable, cost efficient electrolysers installed around the globe, Nel Hydrogen is the recognized industry leader of Alkaline and PEM water electrolysis.

Since our founding in 1927, sustained R&D efforts have contributed to continual improvement of electrolyser technology, setting the benchmark in the market. Our electrolysis technology is today widely respected for its robustness, reliability and energy efficiency.

Our water electrolysers make a superior choice for Industry, Transport and Power-to-X applications. Multiple, scalable, flexible, modular product ranges are set to meet any customer requirements.

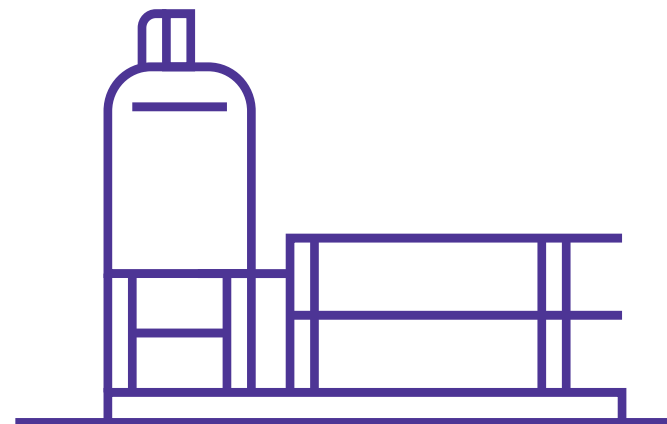

MC250/MC500 Hydrogen Generation System

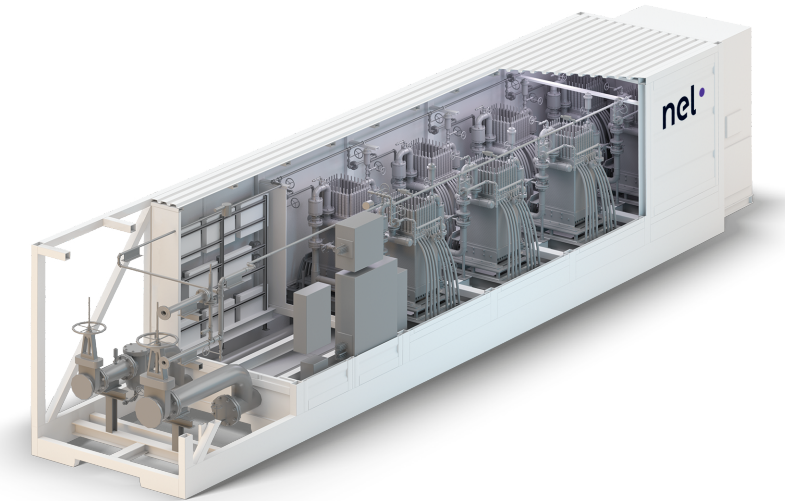

PSM Electrolyser Stack Module



C10/C20/C30 Hydrogen Generation System

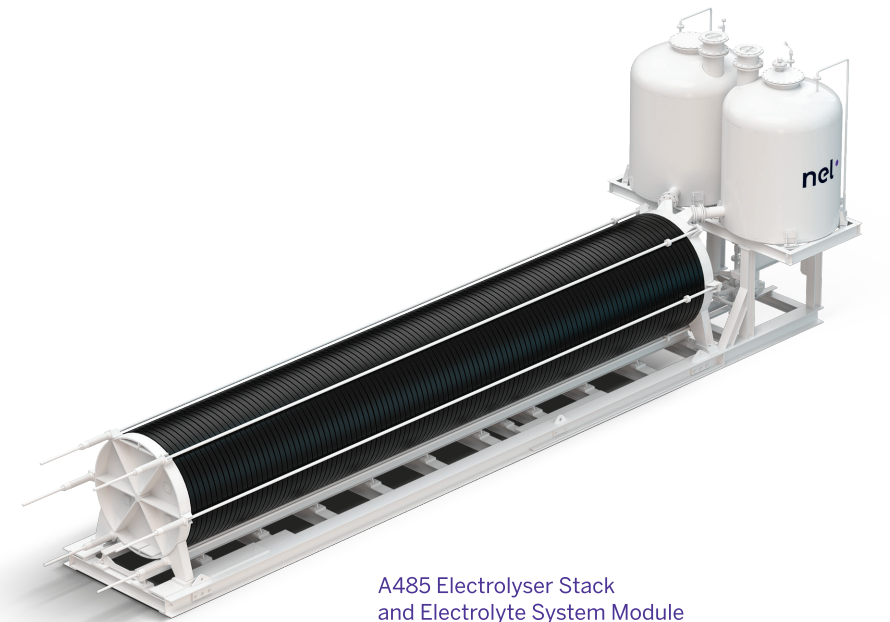

A485 Electrolyser Stack and Electrolyte System Module



H2/H4/H6 Hydrogen Generation System



S10/S20/S40 Hydrogen Generation System

The Atmospheric Alkaline Hydrogen Plant

Nel Hydrogen Atmospheric Alkaline water electrolyzers consist of standard modules of proven technology, critical for a hydrogen production process that is efficient, safe and reliable.

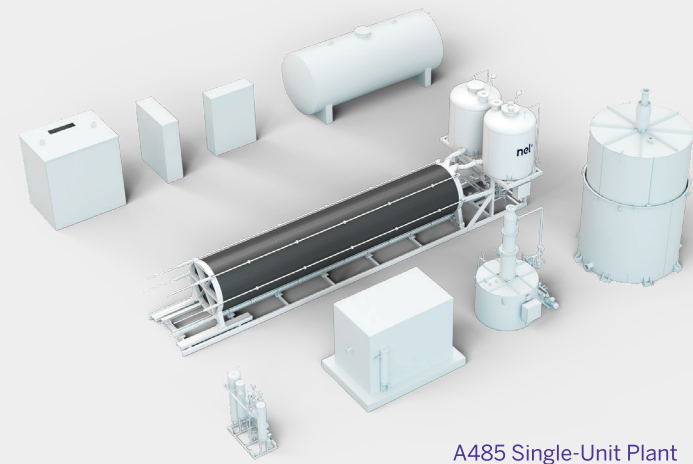

A485 Single-Unit Plant

Electrolysis is the process of splitting the water molecule into hydrogen and oxygen using electricity. The inputs to this process are simply feed water and the current supplied to the electrolyser.

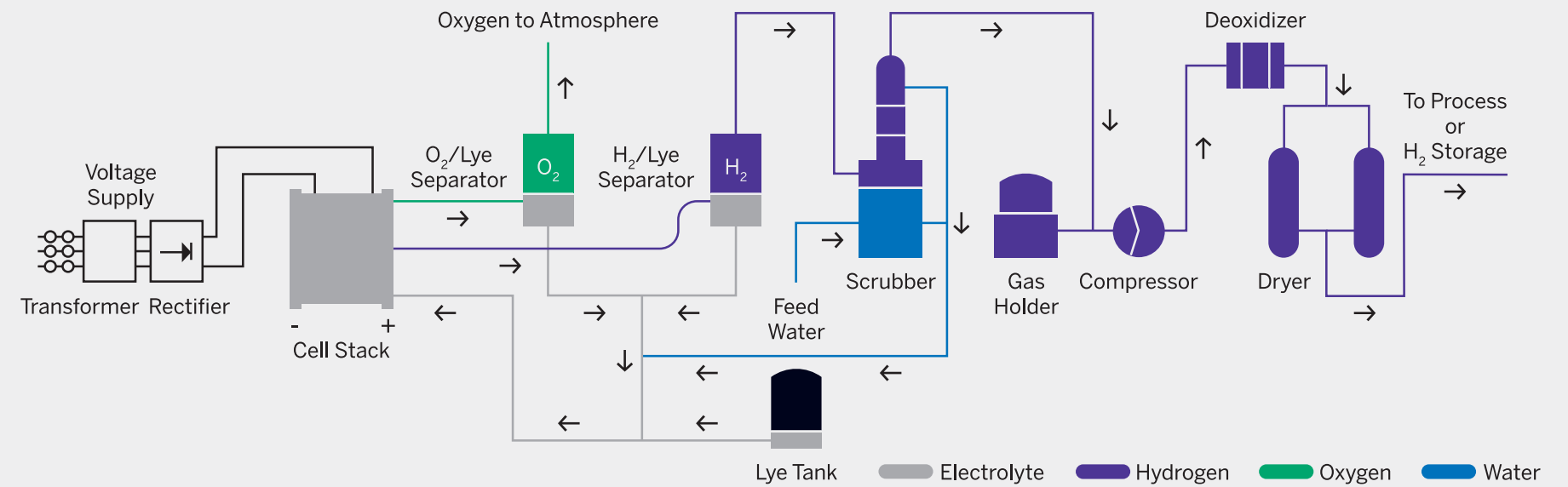

TRANSFORMER/RECTIFIER

The transformer and rectifier convert the AC voltage supply into DC current input at the required voltage.

CELL STACK

The electrolyser is of the filter press type with bipolar electrodes separated by non-asbestos diaphragms. Hydrogen gas is generated at the cathode and the oxygen gas at the anode.

ELECTROLYTE SYSTEM

This module consists of two gas separators and the electrolyte recirculation system. The electrolyte is recovered in the separators, then chilled and recycled into the cell block.

SCRUBBER

The scrubber has three main functions:

- Remove residual traces of electrolyte
- Cool down the hydrogen
- Feed water tank

GAS HOLDER

The gas holder is a buffer tank installed between the electrolyser and the compressor or the process at site.

COMPRESSOR

If required, a compressor is installed to compress the gas from atmospheric pressure in the gas holder to the pressure required for the process or the storage vessel.

DEOXIDIZER

Hydrogen generated in the electrolyser is a very pure gas, saturated with water, and its oxygen content doesn't exceed 0.2%. If higher purity is required, the last molecules of oxygen can be removed by catalytic reaction in a deoxidizer.

DRYER

The dryer will dry the gas to reach the suitable dew point. It consists of twin towers filled with a regenerative desiccant to absorb the water.

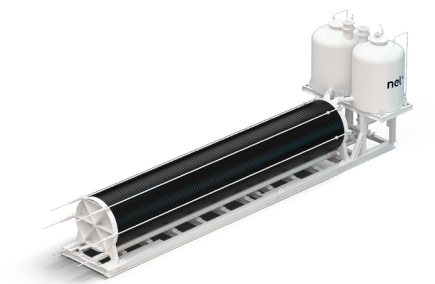

A Series

A Series electrolyzers are based on our proven 2.2 MW modular A485 design. With a power consumption at the stack of 3.8 to 4.5 kWh/Nm³ of hydrogen gas produced, they are the world's most energy efficient electrolyser. Utilizing this core technology, customers are able to build complete hydrogen plants at scale, reaching into the hundreds of MW and even the GW levels.

Modular Design

The A485 is an atmospheric bi-polar alkaline electrolyser cell stack coupled to a matching electrolyte system. The stack consists of 230 cells assembled on a self-supporting rigid steel frame. As DC voltage is applied between the first and last electrodes, current flows through the cells, splitting water molecules to generate hydrogen and oxygen gas.

Each cell is composed of an anode and a cathode, separated by a woven non-asbestos diaphragm which is integrated in a synthetic rubber frame. The gas from each cell is collected in the hydrogen and oxygen flow ducts which feed the gas into the electrolyte system.

The electrolyte system consists of two gas separators, water seals, a lye circulation unit and a support frame. The main functions are to separate the gases (H₂ and O₂) from the lye coming from the cell stack and to cool and circulate the lye back to the stack.

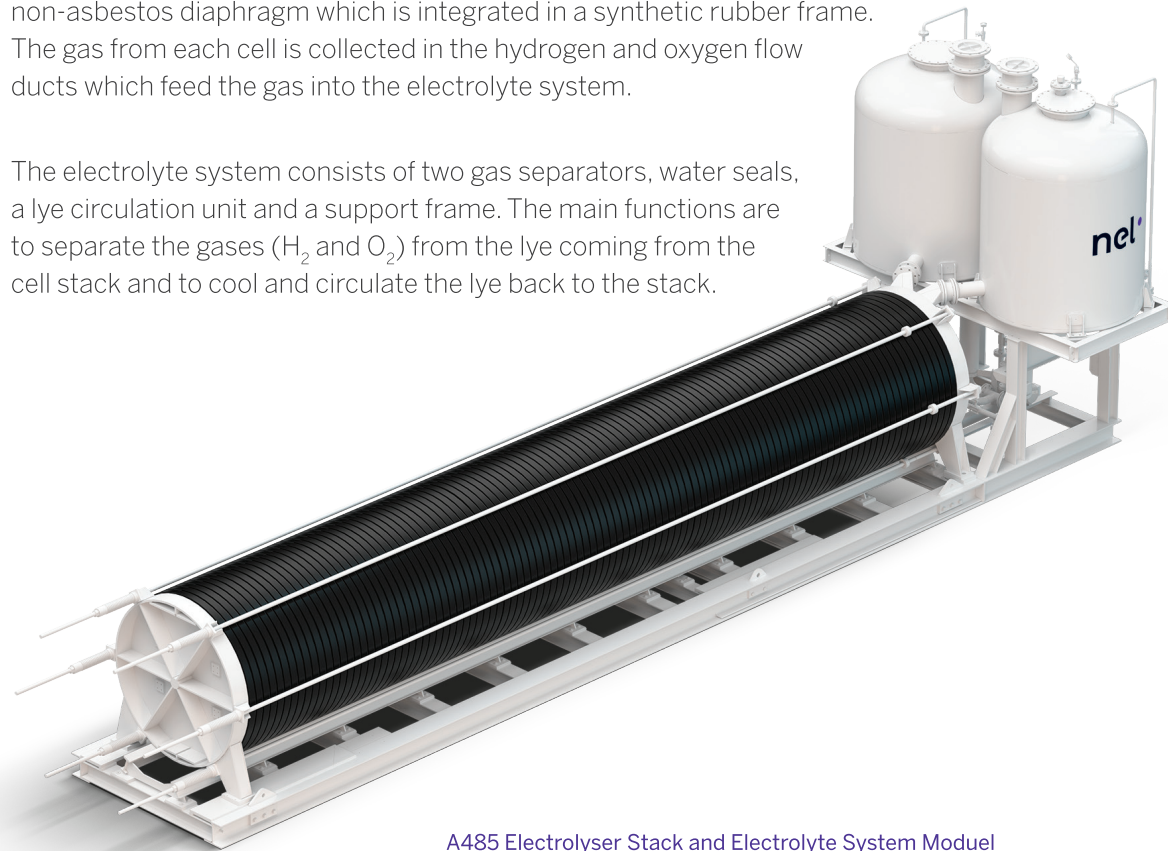

A485 Electrolyser Stack and Electrolyte System Modul

SPECIFICATIONS

	A485 Module
Net Production Rate	485 Nm ³ /h (+0/-3%) 1.046 kg/24 h (+0/-3%)
Turndown Range	15 to 100%
Power Consumption at Stack at 100% Capacity ¹	4.5 kWh/Nm ³ (±0.1%) 50 kWh/kg (±1.1%)
Purity (concentration of impurities)	99%+ [saturated gas with liquid water, O ₂ < 1 %]
Operating Pressure	0.03 barg (0.435 psig)
Dimensions – W x D x H	14.1 m x 4.3 m x 4.3 m (46.3 ft x 14.1 ft x 14.1 ft)
Ambient Temperature ²	5 to 45°C (41 to 113°F)
Electrolyte	25% KOH solution
Feed Water Consumption, electrolysis	0.9 l/Nm ³ (0.24 gal/Nm ³) of H ₂ 10 l/kg (2.64 gal/kg) of H ₂

For reference only – specifications are subject to change. Please contact Nel Hydrogen for solutions to best fit your needs.
¹ Beginning of life and dependent on configuration and operating conditions.

Scalable to Large Plants of Any Size

Whether you need large quantities of hydrogen for industrial purposes, or utilization of excess renewable energy for energy storage – we have experience in both fields!

Nel Hydrogen is the acknowledged expert in large scale electrolysers. The very nature of the A Series is its seamless capacity to upsize from medium to large scale hydrogen plants based on water electrolysis technology.

Any plant size is feasible by simply connecting the required number of A485 modules together. For Large Scale Plants, Nel scope of supply is typically limited to the Stacks with ES modules and the Control and Safety System for the low pressure part of the System.

The power supply and the downstream system (scrubber, gas holder, compressors, dryer, deoxidizer and storage are typically project specific and handled by the customer/customer EPC.

Nel provides engineering support on upstream and downstream equipment (BoP) and recommendations for the building design.

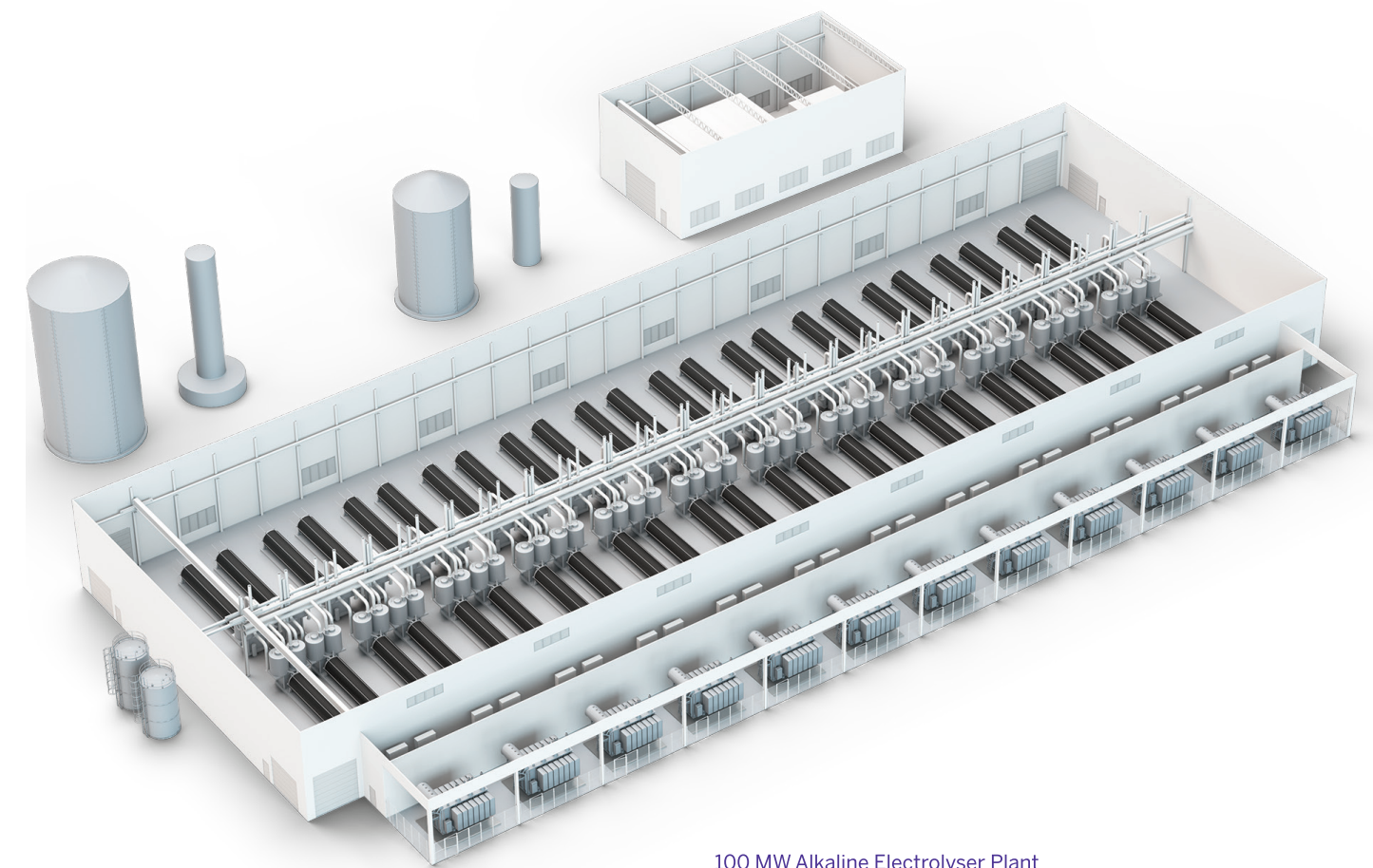

100 MW Alkaline Electrolyser Plant

The Proton Exchange Membrane (PEM) Hydrogen Plant

Nel Hydrogen PEM water electrolyzers are designed to meet the specific needs of high purity industrial applications. These state-of-the-art units offer turnkey solutions for the growing need for stable, cost-effective, high volume hydrogen supply.

Electrolysis is the process of splitting the water molecule into hydrogen and oxygen using electricity. The inputs to this process are simply feed water and the current supplied to the electrolyser.

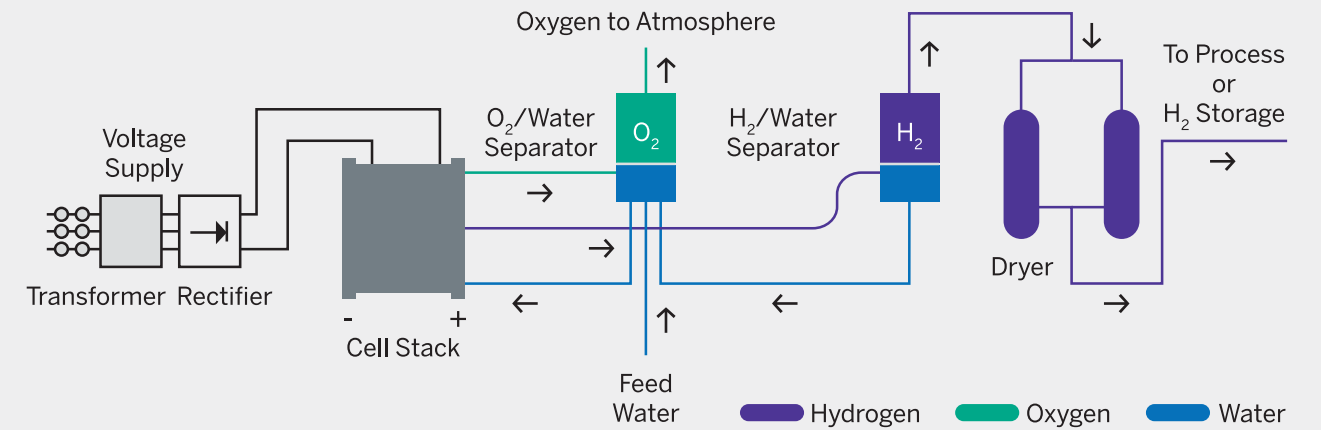

TRANSFORMER/RECTIFIER

The transformer and rectifier convert the AC voltage supply into DC current input at the required voltage.

CELL STACK

The electrolyser is based upon proton exchange membrane technology. Hydrogen gas is generated at the cathode at elevated pressures up to 30 barg. Oxygen gas is produced at the anode at customer convenient pressures. The full differential pressure design provides for safe, simple operation.

H₂/WATER SEPARATOR

The H₂/Water Separator removes liquid water from the high pressure hydrogen and recycles it back to the system water tank.

DRYER

The dryer will dry the gas to reach the suitable dew point. It consists of multiple beds filled with a regenerative desiccant to absorb the water.

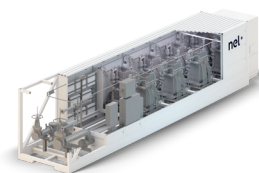

PSM Series

PSM Series electrolyzers are based on our state-of-the-art 10 MW modular PSM design. Each unit houses eight 1.25 MW PEM stacks and can produce up to 2,020 Nm³/h or 4,300 k/24 h of hydrogen gas at 99+% purity. These units can be sited outside and form the foundation for large electrolyser plants at scale.



MC Series

With minimal maintenance and siting requirements, containerized MC Series electrolyzers can produce up to 492 Nm³/h of hydrogen gas at 99.999+% purity on-demand. Featuring a modular design with units that can be grouped together, these systems offer solutions that are well-suited for a variety of industrial applications.



C Series

The C Series electrolyzers are ideal for a variety of industrial applications. Producing up to 30 Nm³/h of hydrogen gas at 99.999+% purity, these units replace the need for hydrogen tube trailers or liquid hydrogen storage. They are easy to install and operate.



H Series

The H Series electrolyzers offer turnkey solutions for small-scale applications requiring up to 6 Nm³/h of hydrogen gas at 99.999+% purity. These units make a minimal impact to facility floor space and are easy to maintain.



S Series

Producing high purity hydrogen of 99.999+% at up to 1.05 Nm³/h, S Series electrolyzers replace the need for hydrogen cylinders in a variety of industrial processes. Each unit is low maintenance, compact, quiet, and can be installed virtually anywhere in a facility.

Modular Design

The PSM is a proton exchange membrane (PEM) based water electrolyser module that integrates eight 1.25 MW cell stacks to generate hydrogen from deionized (DI) water and four DC electrical power inputs. The unit includes the PEM cell stacks, associated piping, DC power connections, and related critical monitoring instrumentation.

Employing a modular approach to hydrogen production, the PSM is designed to offer guaranteed, repeatable performance per module to provide a cost-effective solution for hydrogen production at all scales, from MW to GW projects.

- Containerized electrolyser stack module for easy plant integration
- Site ready design eliminates the need for a building and reduces construction cost
- Pre-integrated stacks reduce installation time and risk
- Instrumentation for critical process and safety monitoring included in package
- Assembled and pre-tested at factory to assure quality control

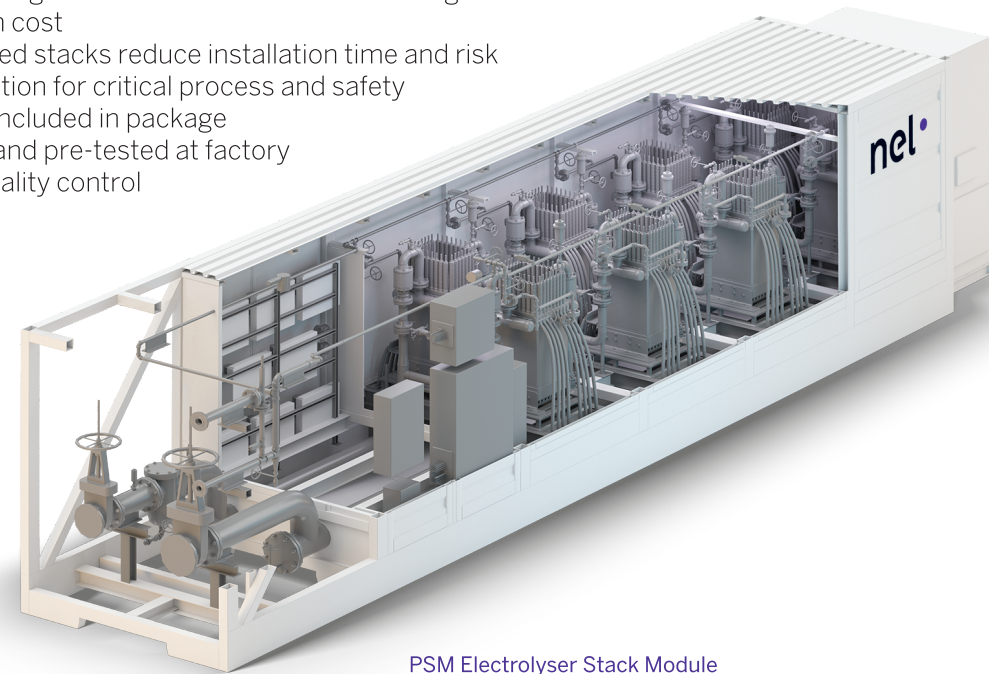

PSM Electrolyser Stack Module

SPECIFICATIONS	PSM Module
Net Production Rate	2,020 Nm ³ /h 4,300 kg/24 h
Turndown Range	10 to 100%
Power Consumption at Stack at 100% Capacity ¹	4.5 kWh/Nm ³ 51.2 kWh/kg
Purity (concentration of impurities)	99%+ [saturated gas with liquid water, N ₂ < 2 ppm, O ₂ < 1 ppm, all others undetectable]
Operating Pressure	30 barg (435 psig)
Dimensions – W x D x H	13.4 m x 2.4 m x 2.9 m (44 ft x 7.9 ft x 9.5 ft), without vent stack
Ambient Temperature	-30 to 50°C (-22 to 122°F)
Electrolyte	Proton Exchange Membrane
Feed Water Consumption, electrolysis	0.9 l/Nm ³ (0.24 gal/Nm ³) of H ₂ 10 l/kg (2.64 gal/kg) of H ₂

For reference only – specifications are subject to change. Please contact Nel Hydrogen for solutions to best fit your needs.
¹ Beginning of life and dependent on configuration and operating conditions.

Turnkey MW Solutions

The MC250 and MC500 electrolysers deliver megawatt scale performance in a containerized form for easy outdoor installations. The units feature either one or two 1.25 MW stacks with a shared balance of plant, providing a reliable solution with minimal maintenance. Multiple units can be grouped together for larger hydrogen output needs. Typical applications include renewable energy storage, industrial process gas, and hydrogen fueling.

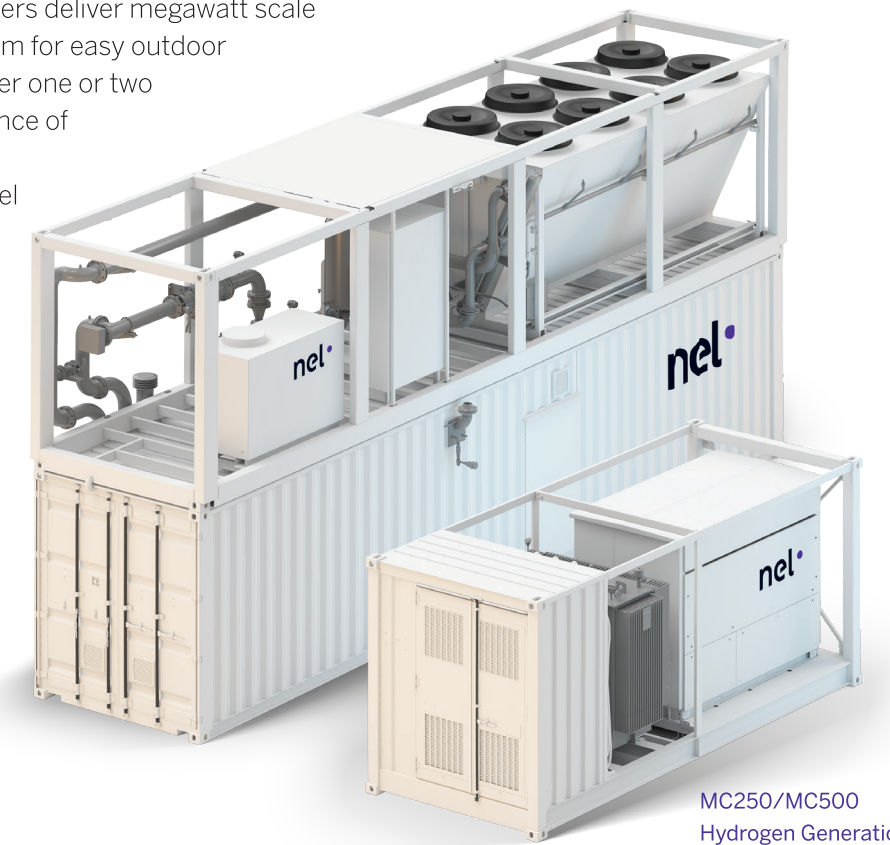

MC250/MC500 Hydrogen Generation System

SPECIFICATIONS	MC250 System	MC500 System
Net Production Rate	246 Nm ³ /h 531 kg/24 h	492 Nm ³ /h 1,061 kg/24 h
Turndown Range	10 to 100% (automatic)	10 to 100% (automatic)
Power Consumption at Stack at 100% Capacity ¹	4.5 kWh/Nm ³ 51.2 kWh/kg	4.5 kWh/Nm ³ 51.2 kWh/kg
Power Consumption by System at 100% Capacity ¹	5.0 kWh/Nm ³ 56.8 kWh/kg	4.9 kWh/Nm ³ 55.2 kWh/kg
Purity (concentration of impurities)	99.95% [H ₂ O < 500 ppm, N ₂ < 2 ppm, O ₂ < 1 ppm, all others undetectable]	99.95% [H ₂ O < 500 ppm, N ₂ < 2 ppm, O ₂ < 1 ppm, all others undetectable]
Purity (concentration of impurities with optional high purity dryer)	99.999+% [H ₂ O < 5 ppm, N ₂ < 2 ppm, O ₂ < 1 ppm, all others undetectable]	99.999+% [H ₂ O < 5 ppm, N ₂ < 2 ppm, O ₂ < 1 ppm, all others undetectable]
Delivery Pressure	30 barg (435 psig)	30 barg (435 psig)
Dimensions	Electrolyser Enclosure ² W x D x H	Electrolyser Enclosure ² W x D x H
	Power Supply Enclosure	Power Supply Enclosure
Ambient Temperature ³	-20 to 40°C (-4 to 104°F)	-20 to 40°C (-4 to 104°F)
Electrolyte	Proton Exchange Membrane	Proton Exchange Membrane
Potable Water Consumption ⁴	1.5 l/Nm ³ (0.4 gal/Nm ³) of H ₂ 15.9 l/kg of H ₂ (4.2 gal/kg of H ₂)	1.5 l/Nm ³ (0.4 gal/Nm ³) of H ₂ 15.9 l/kg of H ₂ (4.2 gal/kg of H ₂)

For reference only – specifications are subject to change. Please contact Nel Hydrogen for solutions to best fit your needs.

¹ Dependent on configuration and operating conditions.

² Plus vent, ground mounted HVAC and rooftop equipment, site specific.

³ Additional low ambient and high ambient temperature options available.

⁴ Potable water quality can affect usage, see SFM1087.

Compact Scale Hydrogen Plants

The C, H and S Series electrolyzers feature state-of-the-art PEM technology in compact forms. They are easy to site in indoor areas.

SPECIFICATIONS		C10 System	C20 System	C30 System
Nominal Production Rate		10 Nm ³ /h	20 Nm ³ /h	30 Nm ³ /h
Turndown Range		0 to 100% (automatic)	0 to 100% (automatic)	0 to 100% (automatic)
Power Consumption by System ¹		6.2 kWh/Nm ³	6.0 kWh/Nm ³	5.8 kWh/Nm ³
Purity		99.999+% [H ₂ O < 2 ppm, N ₂ < 2 ppm, O ₂ < 1 ppm, all others undetectable]	99.999+% [H ₂ O < 2 ppm, N ₂ < 2 ppm, O ₂ < 1 ppm, all others undetectable]	99.999+% [H ₂ O < 2 ppm, N ₂ < 2 ppm, O ₂ < 1 ppm, all others undetectable]
Delivery Pressure		30 barg (435 psig)	30 barg (435 psig)	30 barg (435 psig)
Dimensions – W x D x H	Electrolyser Enclosure	2.5 m x 1.2 m x 2 m (8.2 ft x 3.9 ft x 6.6 ft)	2.5 m x 1.2 m x 2 m (8.2 ft x 3.9 ft x 6.6 ft)	2.5 m x 1.2 m x 2 m (8.2 ft x 3.9 ft x 6.6 ft)
	Power Supply Enclosure	1.7 m x 1 m x 2 m (5.6 ft x 3.3 ft x 6.6 ft)	1.7 m x 1 m x 2 m (5.6 ft x 3.3 ft x 6.6 ft)	1.7 m x 1 m x 2 m (5.6 ft x 3.3 ft x 6.6 ft)
Ambient Temperature		5 to 40°C (41 to 104°F)	5 to 40°C (41 to 104°F)	5 to 40°C (41 to 104°F)
Electrolyte		Proton Exchange Membrane	Proton Exchange Membrane	Proton Exchange Membrane
Feed Water at Maximum Production		9 l/h (2.4 gal/h)	17.9 l/h (4.7 gal/h)	26.9 l/h (7.1 gal/h)

SPECIFICATIONS		H2 System	H4 System	H6 System
Nominal Production Rate		2 Nm ³ /h	4 Nm ³ /h	6 Nm ³ /h
Turndown Range		0 to 100% (automatic)	0 to 100% (automatic)	0 to 100% (automatic)
Power Consumption by System ¹		7.3 kWh/Nm ³	7.0 kWh/Nm ³	6.8 kWh/Nm ³
Purity		99.999+% [H ₂ O < 5 ppm, N ₂ < 2 ppm, O ₂ < 1 ppm, all others undetectable]	99.999+% [H ₂ O < 5 ppm, N ₂ < 2 ppm, O ₂ < 1 ppm, all others undetectable]	99.999+% [H ₂ O < 5 ppm, N ₂ < 2 ppm, O ₂ < 1 ppm, all others undetectable]
Delivery Pressure ²		15 barg (218 psig)	15 barg (218 psig)	15 barg (218 psig)
Dimensions – W x D x H		1.8 m x 0.8 m x 1.9 m (5.9 ft x 2.6 ft x 6.2 ft)	1.8 m x 0.8 m x 1.9 m (5.9 ft x 2.6 ft x 6.2 ft)	1.8 m x 0.8 m x 1.9 m (5.9 ft x 2.6 ft x 6.2 ft)
Ambient Temperature		5 to 50°C (41 to 122°F)	5 to 50°C (41 to 122°F)	5 to 50°C (41 to 122°F)
Electrolyte		Proton Exchange Membrane	Proton Exchange Membrane	Proton Exchange Membrane
Feed Water at Maximum Production		1.83 l/h (0.48 gal/h)	3.66 l/h (0.97 gal/h)	5.5 l/h (1.45 gal/h)

SPECIFICATIONS		S10 System	S20 System	S40 System
Nominal Production Rate		0.27 Nm ³ /h	0.53 Nm ³ /h	1.05 Nm ³ /h
Turndown Range		0 to 100% (automatic)	0 to 100% (automatic)	0 to 100% (automatic)
Power Consumption by System ¹		6.1 kWh/Nm ³	6.1 kWh/Nm ³	6.1 kWh/Nm ³
Purity		99.999+% [H ₂ O < 5 ppm, N ₂ < 2 ppm, O ₂ < 1 ppm, all others undetectable]	99.999+% [H ₂ O < 5 ppm, N ₂ < 2 ppm, O ₂ < 1 ppm, all others undetectable]	99.999+% [H ₂ O < 5 ppm, N ₂ < 2 ppm, O ₂ < 1 ppm, all others undetectable]
Delivery Pressure		13.8 barg (200 psig)	13.8 barg (200 psig)	13.8 barg (200 psig)
Dimensions – W x D x H		0.8 m x 1 m x 1.1 m (2.6 ft x 3.3 ft x 3.6 ft)	0.8 m x 1 m x 1.1 m (2.6 ft x 3.3 ft x 3.6 ft)	0.8 m x 1 m x 1.1 m (2.6 ft x 3.3 ft x 3.6 ft)
Ambient Temperature ³		5 to 40°C (41 to 104°F)	5 to 40°C (41 to 104°F)	5 to 40°C (41 to 104°F)
Electrolyte		Proton Exchange Membrane	Proton Exchange Membrane	Proton Exchange Membrane
Feed Water at Maximum Production		0.26 l/h (0.07 gal/h)	0.47 l/h (0.13 gal/h)	0.94 l/h (0.25 gal/h)

For reference only – specifications are subject to change. Please contact Nel Hydrogen for solutions to best fit your needs.
¹ Beginning of life and dependent on configuration and operating conditions. ² 30 barg (435 psig) option. ³ 5 to 50°C (41 to 122°F) option for S10.

Are You Next?

Hydrogen Business Development

Moving into hydrogen implies new territory and many opportunities. Investing in renewable hydrogen infrastructure requires solid solutions for operation, maintenance, ownership and financing. We realize technological advancement takes place in a wider context in which we can give advice, facilitate and play different roles.

Committed to the success of every customer, Nel Hydrogen has valuable experience across categories, covering most aspects of hydrogen entrepreneurship.

Nel Hydrogen builds hydrogen production facilities of all sizes and configurations. Our largest hydrogen plants to date: 167 MW. Challenge us, and we will be happy to discuss what solutions will fit your needs.

Markets we serve

